

# KM-757 / 757BL Series

High Speed, 2-Needles, Needle Feed,  
Lock Stitch Sewing Machine  
with Automatic Thread Trimmer



Hook		Trimming and Notor	
No Mark	Standard Hook	No Mark	Non-Trimming Type : Clutch Motor
BL	Double-Capacity Hook	7S	Trimming Type : Servo Motor

## Specification

Model	KM-757-7S	KM-757BL-7S
Application	Medium Materials and Heavy Materials	
Max. Sewing Speed	3,000spm	
Max. Stitch Length	5mm	7mm
Needle Bar Stroke	33.4mm	
Thread Take-up Stroke	57.2mm	62.1mm
Height of Presser Foot	Hand : 7mm / Knee : 15mm	
Foot(Automatic)	15mm(Optional Among Trimming Types)	
Hook	Horizon Standard Hook	Horizon Double - Capacity Rotary Hook
Needle	DP×5 #14(#11~#22)	DP×5 #22(#11~#22)
Trimming Device	Trimming (7S) : Servo Motor	
Motor	Non - Trimming(No Mark) : Clutch Motor	

## Option Gauge

\* In case of using over 1-1/2"(38.1mm) guage parts, it is required to make special matching on the arm bed.

Spec.	1/16"	3/32"	1/8"	5/32"	3/16"	1/4"	5/16"	3/8"	7/16"	1/2"	5/8"	3/4"	7/8"	1"	1-1/4"	1-3/8"	1-1/2"	2"	2-1/16"
Model	1.6mm	2.4mm	3.2mm	4mm	4.8mm	6.4mm	7.9mm	9.5mm	11mm	12.7mm	15.9mm	19mm	22.2mm	25.4mm	31.8mm	34.9mm	38mm	50.8mm	52.4mm
KM-757	○	○	○	○	○	○	○	○	○	○	○	○	○	○	○	○	○	*	*
KM-757-7S/7N	○	○	○	○	○	○	○	○	○	○	○	○	○	○	○	○	○	*	
KM-757BL	○	○	○	○	○	○	○	○	○	○	○	○	○	○	○	○	○		
KM-757BL-7S/7N	○	○	○	○	○	○	○	○	○	○	○	○	○	○	○	○	○		

## Application

A needle feed sewing machine that is completely free from unevenness in material feed and material puckering, suitable to fancy stitching for jeans, vinyl or leather, etc.

\* Specifications and appearance are subject to change for the improvement of products without prior notice.

### OVERSEAS MARKETING DIVISION

#178-212, GAJWA-DONG, SEO-GU,  
INCHEON, KOREA  
TEL: 82-32-580-5741-60 FAX: 82-32-584-3025-6

### OVERSEAS NETWORK

| SUNSTAR U.S.A INC |  
TEL: 1-305-591-9596 FAX: 1-305-591-0661  
| SUNSTAR DO BRASIL LTDA |  
TEL: 55-11-3362-3434 FAX: 55-11-3362-3444  
SUNSTAR MACHINERY EUROPE GMBH  
TEL: 43-2236-660-229 FAX: 43-2236-660-2293  
| SUNSTAR MACHINERY (SINGAPORE) PTE LTD. |  
TEL: 65-6227-7545 FAX: 65-6227-7905  
| SUNSTAR JAKARTA BRANCH OFFICE |  
TEL: 62-21-4586-5839 FAX: 62-21-4586-5840

| SUNSTAR DHAKA BRANCH OFFICE |  
TEL: 88-02-881-9153 FAX: 88-02-883-5707  
| SUNSTAR CHITTAGONG BRANCH OFFICE |  
TEL & FAX: 88-031-255-2497

| SUNSTAR BANGALORE BRANCH OFFICE |  
TEL: 91-080-2653-0365/2653-0366  
FAX: 91-080-2653-0367  
| SUNSTAR DELHI BRANCH OFFICE |  
TEL: 91-11-4057-4207/4208/4209  
FAX: 91-11-4057-4235

| SUNSTAR HOCHIMINH BRANCH OFFICE |  
TEL: 84-8-3592-3703 FAX: 84-8-3592-3704  
| SUNSTAR HANOI BRANCH OFFICE |  
TEL: 84-4-3783-1446 FAX: 84-4-3783-1447

### OVERSEAS NETWORK

| SUNSTAR MACHINERY(SHANGHAI) CO.,LTD. |  
TEL: 86-21-6957-6308-6312  
FAX: 86-21-6957-6093  
| SUNSTAR MACHINERY(SHANGHAI) CO.,LTD.  
MARKETING DIVISION |  
TEL: 86-21-6353-2233 FAX: 86-21-6353-8640  
| SUNSTAR QINGDAO BRANCH OFFICE |  
TEL: 86-532-6691-1236 FAX: 86-532-6691-2262  
| SUNSTAR NANJING BRANCH OFFICE |  
TEL: 86-25-8459-4758 FAX: 86-25-8459-4408

| SUNSTAR HANGZHOU BRANCH OFFICE |  
TEL: 86-571-8577-9479 FAX: 86-571-8577-9478  
| SUNSTAR JINAN BRANCH OFFICE |  
TEL: 86-531-8592-8258 FAX: 86-531-8592-8358

| SUNSTAR DONGGUAN BRANCH OFFICE |  
TEL: 86-769-2234-4043 FAX: 86-769-2234-4042  
| SUNSTAR FUJIAN BRANCH OFFICE |  
TEL: 86-595-8859-8871 FAX: 86-595-8859-8872  
| SUNSTAR ANHUI BRANCH OFFICE |  
TEL & FAX: 86-551-424-8000

| SUNSTAR WUHAN BRANCH OFFICE |  
TEL: 86-27-8375-3080 FAX: 86-27-8375-0371

### WEB - SITE

<http://sunstar.co.kr>

### E - MAIL

[marketing@sunstar.co.kr](mailto:marketing@sunstar.co.kr)

**SunStar** SunStar CO., LTD.



Find your Solution  
**SunStar**



# KM-757/757BL Series

High Speed, 2-Needles, Needle Feed,  
Lock Stitch Sewing Machine with Automatic Thread Trimmer





# KM-757/757BL Series

High Speed, 2-Needles, Needle Feed, Lock Stitch Sewing Machine with Automatic Thread Trimmer

## New, Twin Needle Sewing Machine Series Developed Through The Advanced Technology of SunStar!

A new, higher level of advanced mechatronics has been ideally achieved by the grafting of the newly developed, automatic thread trimming FORTUNA III AC SERVO MOTOR, equipped with the most up-to-date function, to our new twin-needle sewing machine ; varied functions created for operational convenience. This new product will contribute greatly to upgrading variable of sewing pattern quality and to increased productivity.

### >> Simplified thread trimming structure

The simplified thread trimmer operating structure makes adjustment, disassembly and assembly of the sewing machine much easier (KM-757(BL)-7S(N)).

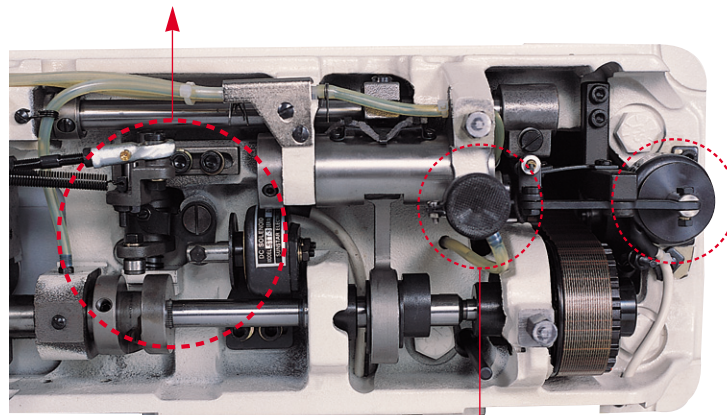

### >> Full automatic lubricating system

The automatic lubricating system eliminates oiling. The pump improves durability of the sewing machine and prevents staining of the fabric from oil.

### >> Solenoid-based thread release structure

The length of the remaining upper thread after trimming can be freely adjusted by controlling the control box volume (KM-757(BL)-7S(N)).



### >> Large hook installation

Owing to the fitting of a large hook, double quantity of lower threads can be secured promoting work efficiency (BL type) compared to normal hook.

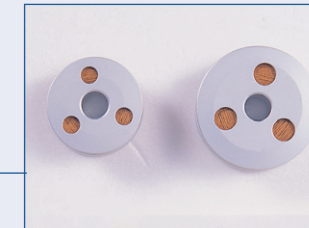

### >> Built-in synchronizer

Synchronizer installed in pulley is more simple and adjusted easily. (KM-757(BL)-7S)



### >> Convenient bobbin thread check system

Thread remaining in the bobbin can be verified easily through inspection windows installed on the left and right sides of each board.



### >> Thread trimming Mes structured for high reliability and wide operating periphery

- Because the Mes is structured to offer a long-life. Plane surface action capable of perfectly cutting thin or thick thread, no Mes re-adjustment is required at all when stitch lengths are changed.
- The wide operating periphery of the thread trimming Mes makes for easy assembly and disassembly. (KM-757(BL)-7S(N))



### >> Separated adjustment of left and right thread tension

The thread adjusting device is able to control the tension of left and right upper threads separately. In any condition, clean and high-quality sewing is guaranteed.

